

19th STREET MARKET APPLICATION GUIDEBOOK

Health Products
Campaigns
Jewelry
Shave Ice
Art Work
Toys
Books
Games
Hot Tubs
Fudge
Hats
Clothing
Sunglasses
Appliances
Home Décor
Beauty Products



Westerner Park

Table of Contents

Welcome to Westerner Park	3
2010 Statistics	3
19 th Street Market	3
Rental Rates	4
Booth Rental Includes	4
Hours of Show Operation	4
Move In	5
Move Out	5
Shipments	5
Application Status Notification & Application Process	6
Payment of Rental Charges	6
Non Payment of Charges	6
Liability Insurance Requirements	7
Failure to Appear	7
Cancellation Policy	7
Pass Information	8
Free Draws & Give-A-Ways	8
Not Acceptable	9
Exclusive Supply and Advertising	9
Product Pricing	9
Goods & Services Tax	10
Personal Services	10
Selling, Handling or Sampling Food	10
Preferred Display Technique	11
Fire Regulations	11
Security	11
Display Sidewall & Height Restrictions	12
Rear Wall Signage & Height Restrictions	13
Accommodations	13
Additional Power, Tables & Tradeshow Equipment	14
Telephone & Internet Service	14
Rules, Regulations & Conditions	14
Conduct of Show	14
Floor Plan	15

Westerner Park

Welcome to Westerner Park

Westerner Park will provide the premier trade, agriculture, sports, entertainment, and conference and meeting facilities in Western Canada, driving economic and community benefits for Red Deer and Central Alberta. Westerner Park is a not-for-profit organization which demonstrates its' vital role in the community through our annual Westerner Days Fair & Exposition, year-round facilities, products and services and agricultural programs that foster understanding of the agricultural industry. All revenues generated are re-invested into our various programs and facilities.

Westerner Days Fair & Exposition 2010 Statistics

Total Gate Attendance	92,689
Wednesday Attendance	15,410
Thursday Attendance	18,056
Friday Attendance	24,302
Saturday Attendance	22,048
Sunday Attendance	12,873

19th Street Market

19th Street Market, located right on the pedestrian boulevard, offers world wide exhibitors a place to showcase their products and services to Central Alberta. We welcome over 90,000 guests each year to Westerner Days Fair & Exposition approximately 47% of all fair patrons visit our event specifically for commercial exhibits. (Independent survey completed in 2008). Our attendees love to shop, especially when it is hot outside, so we offer them an air conditioned building in which to find exactly what they are looking for. Guests can find toys, books and games to play. They can take home saunas, hot tubs or snuggly blankets. Get great ideas for decorating their new homes and get suited up with leather, fashion wear, sports wear or the perfect hat. Nail art, health and wellness products and skin care entice many. Attendees can shade their eyes, shine up their jewelry and get some new pieces while they're here. Indulge in a flavored shave ice or home made fudge. 19th Street Market has it all and we're excited to see all the new products for 2011!

Rental Rates & Show Hours

Rental Rates 2011

Exhibit Booth (10 ft x 10ft)	\$375.00	Exhibit Booth (10 ft x 20 ft)	\$750.00
Corner Exhibit Booth (10 ft x 10ft)	\$475.00	Corner Exhibit Booth (10 ft x 20 ft)	\$850.00
Concession Booth	\$525.00		

Booth Rental Includes

10 ft x 10 ft space or 10 ft x 20 ft

8 ft draped back wall

3 ft draped side wall

1 - 110 Volt **Power** Outlet

2 Weekly parking passes

3 Weekly admittance tickets

- Tables, chairs and carpet are **not** included in booth rental. Each exhibitor is to arrange for these additions with GES Canada Exhibition Services 403.347.7144.
- Each booth is a 10 x 10 ft or 10 x 20 ft space and may be purchased in multiples to provide enough space for each Licensee. The exhibitor is prohibited from assigning or apportioning the whole or any part of the space allotted for **exhibiting or selling any merchandise other than those listed on the License Agreement.**

Hours of Show Operation

Wednesday, July 20	12:00pm – 10:00pm
Thursday, July 21	12:00pm – 10:00pm
Friday, July 22	12:00pm – 10:00pm
Saturday, July 23	12:00pm – 10:00pm
Sunday, July 24	12:00pm – 8:00pm

- Each exhibitor will take possession on move in and agrees to man display for all hours of the show listed above. All displays must be fully set up, stocked and manned during all show hours. Exhibits must not be taken down or removed until 8:00pm Sunday.
 - **A penalty charge of \$100.00 will apply** if exhibitor does not comply with hours of operation.
-

Move In & Move Out

Move In

Tuesday, July 19	8:00am – 8:00pm
Wednesday, July 20	8:00am – 11:00am

Vendor packages will be available for pick up on Tuesday, July 19 at 8:00am. Prior to setting up your exhibit, you are required to pick up your move in package at the east overhead door in Prairie Pavilion. Please allow sufficient time when picking up your package, to review that all passes that were pre-ordered are included in your package. A designated representative will be required to sign for these.

If packages are **not** picked up by 9:00am Wednesday, July 20, your space may be released and resold. If you are unable to pick up your package prior to this time, please notify the Show Coordinator of your anticipated arrival time. Exhibitor will be responsible to pay for entrance and parking, with no re-imbusement, if they fail to notify the Show Coordinator of late arrival. You will be required to pay for entrance and parking after 9:00am, with no refunds.

Move Out

Sunday, July 24	8:00pm – 12:00am
Monday, July 25	8:00am – 12:00pm

Exhibitors must remove their exhibit or concession from Westerner Park at show closing 8:00pm Sunday (no sooner), leaving the booth location clear and free of any debris or garbage, by 12:00pm Monday. Any exhibit or concession not removed by that time will be removed and stored at exhibitor(s) expense. Exhibitor absolves Westerner Park from any liability or claim with respect to such action taken after move out date.

Shipments

You are **not** permitted to ship displays or materials to Westerner Park, as we are unable to sign for any items. If you are sending your materials via a delivery service, you must make prior arrangements to meet them and escort them into the Park.

Application Status & Payment Information

Application Status Notification & Licensing Process

Applications are initially reviewed upon receipt. Full payment of booth is to be sent with the completed Application Form. Incomplete applications, applications that conflict with existing sponsorship contracts, or applications that fall into the 'Not Acceptable' category as defined below will be returned immediately with deposit. All applicants who submit an application will be notified of their status either by a license offer or a letter of explanation.

First Round Applications Received	Jan 1 – Jan 31, 2011
First Round Notification of Status	Feb 1 – Feb 28, 2011
First Round Licensing	Mar 1 – Mar 31, 2011
Second Round Applications Received	Feb 1 – Feb 28, 2011
Second Round Notification of Status	Mar 1 – Mar 31, 2011
Second Round Licensing	Apr 1 – Apr 30, 2011

This process will continue until all available space has been allocated, however, we encourage individuals to continue to submit applications up to July 1, in the event we receive last minute cancellations.

Payment of Rental Charges

Signed Exhibitor Applications with a full payment (including selling privileges) is due no later than July 1, 2011. Non payment of booth rental will result in immediate cancellation of space allocation. Extra admit tickets and parking passes are available at a discounted rate from Show Coordinator.

Non Payment of Charges

Should any charges remain unpaid at the close of Westerner Days Fair & Exposition, any articles, goods and equipment in the said exhibitor's booth may be held by Westerner Park until payment in full is made for which Westerner Park shall be deemed to have a lien on the said good and chattels.

Insurance and Cancellation

Liability Insurance Requirements

All applicants successful in being licensed for the 2011 19th Street Market **must** execute a License Agreement. Each exhibitor is **required** to provide a Certificate of Insurance with a minimum limit of \$1,000,000.00 coverage for each occurrence, prior to move in. Your insurance policy must name Westerner Exposition Association as co-insured and must be submitted with your contract.

In general, the License Agreement provides that each applicant will be liable at all times and will hold harmless and indemnify Westerner Exposition Association for all costs, expenses and damages they may suffer as a result of, but not limited to, those items listed below:

- Injury to or death of the applicants own employees and contractors;
- Loss of or damage to the applicants own property and that of its employees and contractors;
- Any loss, direct, indirect or consequential, that the applicant, its employees or contractors may suffer as a result of an interruption to the business of the applicant regardless of how caused;
- Any and all types of losses suffered by any parties arising from the applicants operations.

Failure to Appear

In the event of an Exhibitor's failure to occupy the space allotted to them by 9:00am Wednesday, July 20, 2011, Westerner Park will assume that the exhibitor has decided not to attend and the space will be allocated to someone else. No Refund will be made to this late exhibitor.

Cancellation

The Exhibitor may cancel this contract with written notice up to 60 days prior to show opening. The amount paid will be refunded less \$25.00 administration fee.

No refunds will be made for cancellations less than 60 days from date of show.

Passes, Draws & Giveaways

Pass Information

All exhibitors and staff, are required to have appropriate accreditation (passes) to enter Westerner Park, Prairie Pavilion where the 19th Street Market is located. Order forms for passes and services will be sent after your license has been executed by Westerner Park. Payment for all services and passes are due no later than July 1, 2011.

Each Booth is provided **2 Weekly Parking Passes** and **3 Weekly Admittance Tickets**.

Additional Weekly Parking Passes (5 day entry)	\$25.00
Additional Daily Parking Passes (one time entry)	\$6.00
Additional Weekly Admittance Passes (5 day entry)	\$25.00
Additional Daily Admittance Passes (one time entry)	\$6.00

Westerner Park gate attendants have been instructed to only allow vehicles and exhibitors in the Park with the appropriate passes. If you misplace your passes, you may purchase additional passes from the Show Office, located at the overhead door in the Prairie Pavilion. **Without passes you are required to pay for entrance and parking with no refunds.**

Free Draws & Give-A-Ways

Unless prohibited by law, successful Licensee's may conduct free draws or give-a-ways within their licensed area. Free draws or give-a-ways means:

- No purchase, donation or demonstration is required to enter the draw to receive a prize or give-a-way.
 - Prizes or give-a-ways where the patron is required to register for a product, donate to a cause or purchase an item, are prohibited.
 - Give-a-way items may include pens, pencils, key chains, magnets, etc.
 - Items that will not be allowed for give-a-way are balloons, stickers, gum.
 - Give-a-way items should not conflict with merchandise sold by other vendors.
 - Food samples are not considered give-a-way items.
 - All draws for prizes conducted on Westerner Park must be completed prior to the close of the show.
-

Product Regulations

Not Acceptable

This applies to all 19th Street Market Exhibitors. Applications received that fall into any or all of the following categories will not be considered, and will not be returned:

- Obscene or offensive products (as determined by Westerner Park Management).
- Pyramid sales, jam auctions, or card table exhibits.
- Raffles, fundraising and/or solicitation of funds on behalf of charitable or non profit organizations.
- Products not meeting Canada Consumer and Corporate Affairs Regulations or products not C.S.A. approved.
- Tobacco products—including cigars, cigarettes and lighters.
- No folding, pocket or hunting knives, swords, daggers or guns of any kind.
- No display, sales or advocacy of items or paraphernalia that may promote in any way the use of illegal drugs.

Exclusive Supply & Advertising

Westerner Park is proud of its corporate partnerships. These agreements provide for exclusive product supply on Westerner Park. The Show coordinator will keep all licensed vendors updated as to new sponsors after the printing of this application manual, where possible conflict may arise.

EXCLUSIVE PRODUCT SUPPLY

Coca-Cola Any soft drinks, juices, juice drinks, isotonic, energy drinks, ready-to drink iced teas and coffees, and bottled water must be Coca Cola brands. These brands include; Coca-Cola, Sprite, Minute Maid, Fruitopia, Five Alive, Nestea, PowerAde, Dasani and others.

Molson Canada Any malt-based beverages must be Molson Canada brands. These brands include Canadian, Coors Light, Rickard's Red, Mike's Hard products.

In addition all of the above Exclusive Suppliers are considered Exclusive Advertisers.

Consideration for licensing food products inside the 19th Street Market are: candy, nuts, fudge, pre-packaged specialty items, mini-donuts, snow cones and lemonades. Food products in conflict with year round Westerner Park operated concessions are not eligible for licensing.

Product Pricing

Price discounting of product(s) and/or service(s) after the show has opened has in the past, created negative feedback from guests. Due consideration should be given when pricing your product or service.

Sales Regulations

Goods & Services Tax

Goods and Services Tax is commonly referred to as GST. Most goods and services (including imported goods) are taxed at a rate of five per cent (5%) on the selling price, there are very few exceptions. The GST is a multi-stage sales tax on consumption and is similar to value-added taxes in many other industrialized countries.

If your global sales are more than \$30,000.00 (Canadian) you must become 'registered' for the GST. This will require you to collect the 5% GST on your sales in Canada and make remittance to Canada Customs and Revenue.

To learn more about GST registration please visit the website at cra-arc.gc.ca. If you do not have internet access please call their offices.

Phone (In Canada) 800.461.9999

Phone (Outside Canada) 204.983.3500

Personal Services

Personal services are defined as products or services that entail skin contact (hair clips, temporary tattoos, henna applications, skin creams, nail care etc). You will be required to complete a form detailing infection control for each location. For booths where there may be multiple products, a form for each service must be completed. These products and services must adhere to the guidelines as set forth by the David Thompson Health Region.

David Thompson Health Region dthr.ab.ca or call 403.341.2155.

At no time can any sourced products be in conflict with the official sponsors / suppliers of Westerner Park.

Selling, Handling or Sampling Food

David Thompson Health Region inspects and approves each booth that sells, or samples food for consumption to the public. Serving sizes for sample products must not exceed 56 grams or 54 milliliters. For specific information regarding food and food handling requirements please contact:

David Thompson Health Region

dthr.ab.ca

P 403.341.2155

At no time can any sourced products be in conflict with the official sponsors and suppliers of Westerner Park.

All concession units must have back flow preventers installed and a Health Department Inspection Certificate.

Booth Regulations

Display Wall & Height Restrictions

Each indoor Exhibitor is entitled to a reasonable sight line from the aisle regardless of the size of the exhibit. The objective for Exhibitors is to effectively use as much of the total booth space as possible, and at the same time not cause any interference with the rights of other Exhibitors.

- Due to the changing layout of the exhibit hall, discretion will be used by the Show Coordinator to determine if such sidewall obstructions severely handicap other vendors. In some cases, it may be necessary to adjust your display, so you should be prepared to do so, if requested.
- The following examples show proper and improper booth displays with respect to the side / rear of the booth space. The diagram below depicts the booth as an inline, but the sidewall restriction can apply to corner and island locations as well.

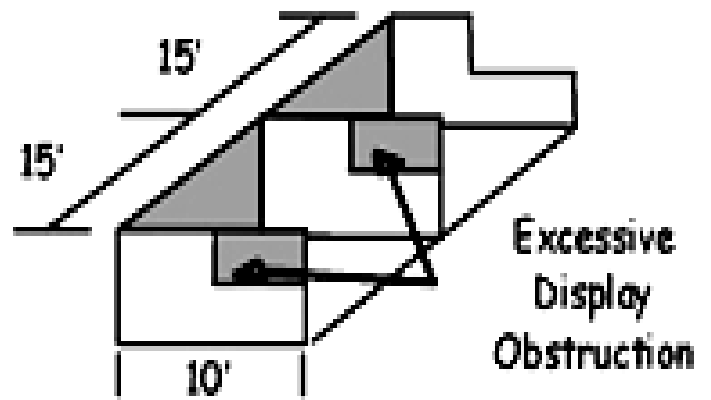
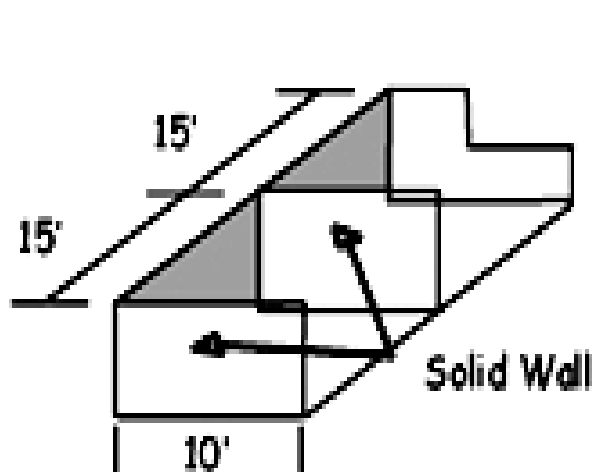
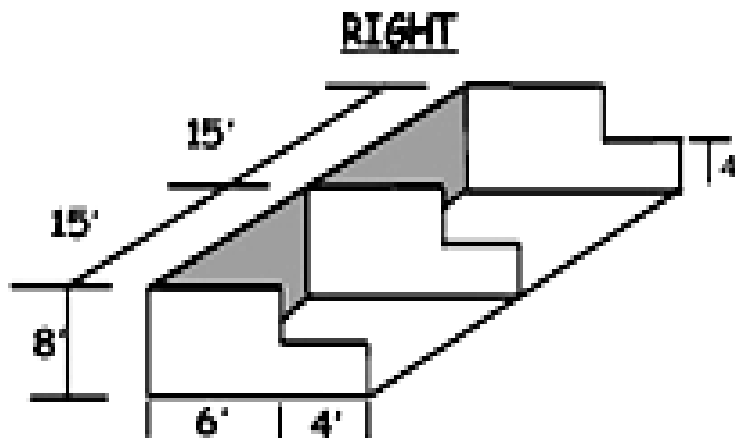

Regulations

Rear Wall Signage & Height Restrictions

Where possible, booths should not exceed the rear wall height restriction of 8'. In some cases, pre-formed booth packages or custom built booths prior to 2004 may, in fact, exceed this height. The Show Coordinator, at their discretion, may determine that the height is too excessive and may request the Exhibitor to make alterations. In some cases, it may be necessary to adjust your display, so you should be prepared to do so, if requested.

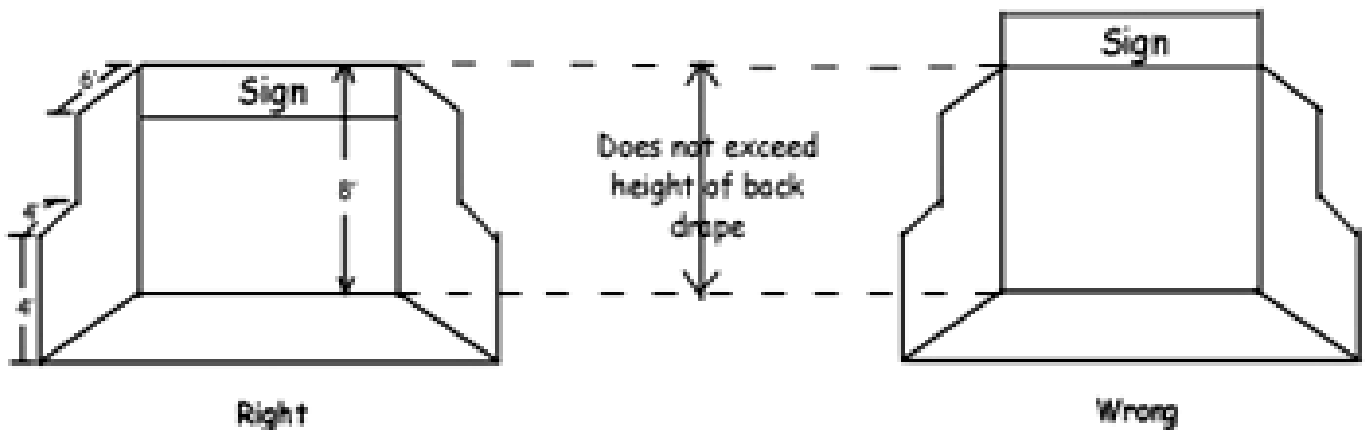

Accommodation

For your accommodation needs, whether hotel, motel, or RV, Tourism Red Deer offers a variety of accommodation possibilities. Westerner Park does offer an on site camp ground and the area also have a variety of hotels and other accommodations near our grounds. Some of these are listed below:

Westerner Campground	403.352.8801
Lions Campground	403.342.8183
Motel 6	403.340.1749
Days Inn	403.340.3297
Western Budget Motel	403.347.2177
Holiday Inn Express	403.343.2112
Capri Hotel & Convention Centre	403.346.2091
Black Knight Inn	403.343.6666
Red Deer Lodge	403.346.8841

Tradeshow Services & Show Regulations

Additional Power, Tables and Tradeshow Equipment

For all additional tables, additional power and tradeshow equipment, Exhibitors are responsible to contact **GES Canada at 403.347.7144.**

Telephone & Internet Service

For all telephone and internet service, exhibitors are responsible to contact **Telebyte at 403.346.9966 or telebyte.ca.**

Rules, Regulations & Conditions

Each exhibitor for the 2011 19th Street Market at Westerner Days Fair & Exposition is required to read and understand the following rules, regulations and conditions. The person signing the contract form or the person on whose behalf he signs, will be held responsible for the implementation of these rules with their staff.

Every effort was made to ensure accuracy and the most up to date available information used, however, policies and pricing are subject to change.

Conduct of Show

Westerner Park reserves the right to require the Exhibitor to remove any item that it deems unacceptable. Westerner Park will **not permit the display, sale, advocacy of items or paraphernalia that or promote in any way the use of illegal drugs or weapons. No knives, swords or other weapons are to be sold or distributed from any booth at any time.**

Management reserves the right to close and remove exhibits or concessions for infractions of any rules.

Floor Plan

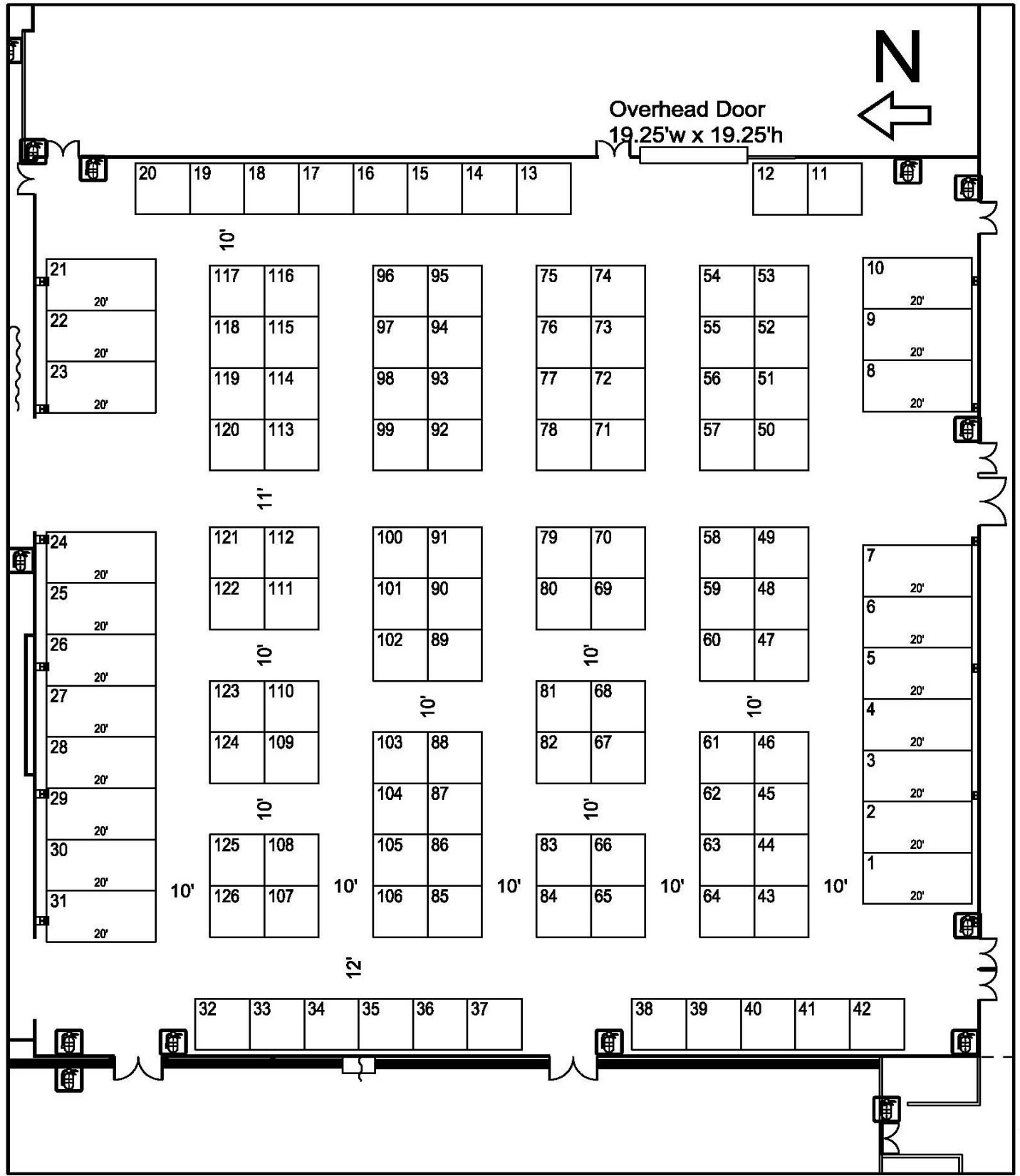

Contact Information

Show Coordinator

Thank you for your interest in our 2011 19th Street Market and for reviewing the rules, regulations and conditions. Enclosed is the contract form for the 19th Street Market. Please complete the contract and return it to our office soon as possible. Your contract will be reviewed and returned to you within the timeline listed inside. Have a great year and we hope to see you at Westerner Days Fair & Exposition.

Show Coordinator

April Weimer

P 403.309.0203
F 403.341.4699
E aweimer@westerner.ab.ca

Westerner Park

4847A 19th Street
Red Deer, AB T4R 2N7
Westernerpark.ca
Westernerdays.ca
